



Ningbo Haitian Precision Machinery Co., Ltd.

H.Q. & Production Base1

No. 1688 Haitian road, Xiaogang, Beilun, Ningbo-315801, China.
Tel: +86-574-86182580/86182525
E-mail: hision@mail.haitian.com

Production Base2

No.235, Huangshan Road, Beilun District, Ningbo-315801 China.

Production Base3

No.188, Baodao Road, Lingang Industrial Zone, Changxing Island, Dalian-116317 China.

Haitian Precision Machinery (HONGKONG) Co., Ltd.

Office Address:

Unit, 12/F, Seabright Plaza, 9-23 Shell Street, North Point, HONGKONG.

Website:

www.haitianprecision.com



NEW 2023-EN-Y-A The text description, pictures and technical parameters in the sample are for reference only, and the changes due to technological development are subject to change without notice.

CNC MACHINE TOOLS FOR DIE CASTING INDUSTRY

HIGH SPEED | HIGH EFFICIENCY | HIGH ACCURACY

CFV | CFV Lite | HPC II | HPC II/D | BEL / BFL | CHM

HISION

PRODUCT INTRODUCTION

Haitian Precision has been keeping up with the pace of the market, devoting itself to the development and research of various types of CNC machine tools to be suitable for different industries and fields. With the increasing demand for lightweight development of automotive and the promotion and application of aluminum die-casting parts, Haitian Precision has flexibly used its own advantages in the machine tool industry and combined its experience in different industry applications to launch five series of high-efficiency processing equipment; CFV series vertical machining centers are mainly suitable for high-speed and high-precision machining of general automotive parts; CFV Lite vertical machining center series is mainly suitable for high speed and efficient processing of 5G filters and electronic control housing of new energy vehicles; HPCII series horizontal machining centers are mainly suitable for high-precision machining of general automotive parts and large die-casting parts; BEL/BFL series high efficiency moving column machining center is mainly suitable for high efficiency processing of large aluminum alloy structural parts; CHM long travel vertical machining center is mainly suitable for efficient processing of strip aluminum alloy.

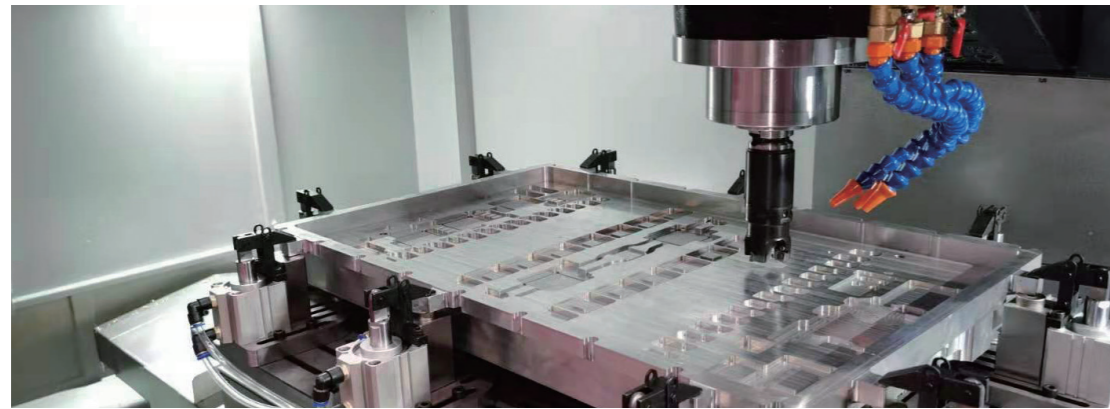

CATALOGUE



CFV VERTICAL MACHINING CENTER

CFV600	[Page 05]
CFV900	[Page 05]
CFV1100	[Page 05]

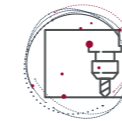

CFV Lite VERTICAL MACHINING CENTER

CFV850 Lite	[Page 08]
CFV1000 Lite	[Page 08]
CFV1200 Lite	[Page 08]

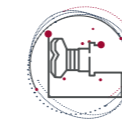

HPC II HORIZONTAL MACHINING CENTER

HPC500 II	[Page 13]
HPC600 II	[Page 13]
HPC650 II	[Page 13]
HPC800 II	[Page 13]
HPC600II/D	[Page 14]
HPC650II/D	[Page 14]
HPC800II/D	[Page 14]
HPC1000	[Page 14]



BEL / BFL HIGH-SPEED MOVING COLUMN MILLING CENTER FOR STRUCTURAL PARTS

BEL2018	[Page 18]
BEL2030	[Page 18]
BFL2018	[Page 18]
BFL2030	[Page 18]



CHM LONG TRAVEL VERTICAL MACHINING CENTER

CHM55020	[Page 22]
CHM55025	[Page 22]
CHM55020B	[Page 22]
CHM55025B	[Page 22]





VERTICAL MACHINING CENTER

CFV

The CFV series innovative technology fully meets the needs of users, and its consistent aim is high efficiency, high precision, and high reliability; the new generation of CFV series vertical machining centers are equipped with advanced built-in spindle series and high dynamic response drive systems to enable processing Higher speed, high precision, and efficiency; and endows environmental protection and energy saving characteristics, which is widely used in the processing of components and mold markets.

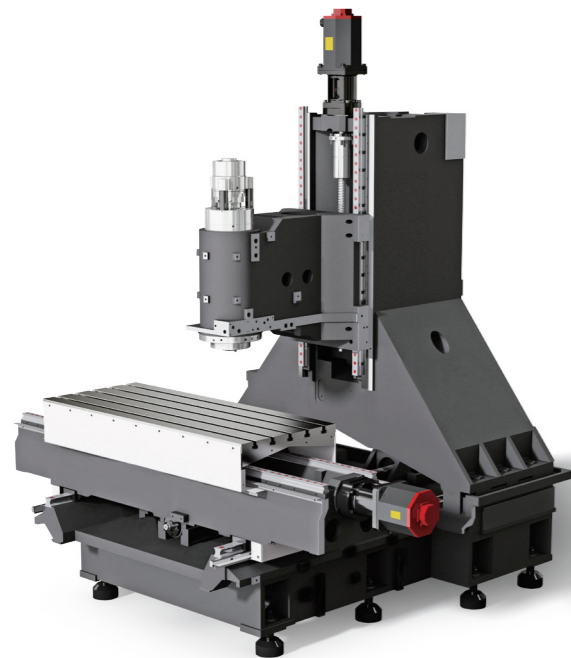

Optimized Component Design

- **High-rigid base components:** large-span bed base, thickened column.
- **Lightweight moving parts:** the total weight of the spindle box and built-in spindle 30% lower than the conventional machines.

High Speed, High Precision Built-In Spindle

- **High precision:** built-in spindle direct drive, no other vibration source.
- **High torque:** two-speed automatic transmission, low speed and high torque, high speed and constant power.
- **Efficient start and stop:** zero drive chain, small inertia, starting from 0 to 8000 rpm in just 0.8 seconds.

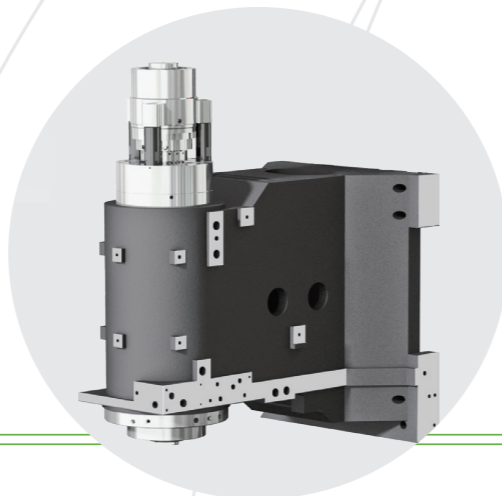

24T Servo Tool Magazine

- **Intelligent preparation tool mode:** shorten non-machining time.
- Max.180mm dia. bridge type boring tool.
- Automatic protection door.
- Heavy tool mode: auto slow tool change in this mode.

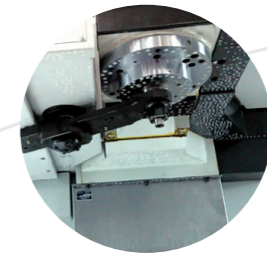

Professional Automation Interface

- Automatic door.
- Automatic line communication interface.
- Tool automatic compensation & life management.
- Tool magazine broken tool detection.
- Workpiece detecting device.
- Option 4th axis & 5th axis.



CFV

Items	Unit	CFV600	CFV900	CFV1100
» Machining Capacity				
X travel	mm	600	900	1100
Y travel	mm	430	430	540
Z travel	mm	510	510	520
Spindle nose to table surface	mm	150-660	150-660	150-670
» Table				
Table size	mm	900×430	1100×430	1300×550
Table loading	kg	500	700	1200
T slot size	mm	3×18×125	3×18×125	5×18×100
» Spindle				
Drive type		Built-in spindle	Built-in spindle	Built-in spindle
Max. Spindle speed	rpm	12,000	12,000	12,000
Spindle power	kW	7.5/11	7.5/11	7.5/11
Spindle torque	N.m	71.6/105	71.6/105	71.6/105
Spindle taper		ISO 7:24 NO.40(BT40)	ISO 7:24 NO.40(BT40)	ISO 7:24 NO.40(BT40)
Pull Stud		MAS-P40T-1 (45°)	MAS-P40T-1 (45°)	MAS-P40T-1 (45°)
» Feed Rate				
Rapid traverse(X/Y/Z)	m/min	36/36/36	36/36/36	36/36/36
Cutting feedrate(X/Y/Z)	m/min	20/20/20	20/20/20	20/20/20
Guideway type		Linear guideway	Linear guideway	Linear guideway
» Tool Magazine				
Tool magazine capacity	T	24	24	24
Tool change type		Arm type	Arm type	Arm type
Max.tool dia. (Adjacent Vacant)	mm	Φ80/Φ150	Φ80/Φ150	Φ80/Φ150
Max. tool length	mm	300	300	300
Max. tool weight	kg	8	8	8
Tool change time (T-T)	s	1.5	1.5	1.5
» Other				
Power capacity	KVA	35	35	35
Machine weight	t	6	7	8
Machine size(L×W×H) (without conveyor)	cm	206×240×266	260×242×258	290×289×268

Standard Configuration

1. Contoller: Mitsubishi M80A
2. 12000rpm built-in spindle
3. Full enclosure with top cover
4. Internal flush chip system (rear) (CFV900、CFV1100)
5. Internal screw chip conveyor (CFV600)
6. 3 color signal lamp
7. Water gun
8. External chain type chip conveyor & trolley (left side) (CFV900、CFV1100)
9. External chain type chip conveyor & trolley (rear) (CFV600)
10. 24T servo ATC (arm type)
11. ATC pneumatic door
12. Hydraulic & grease lubrication system
13. Spindle oil chiller

Processing Range

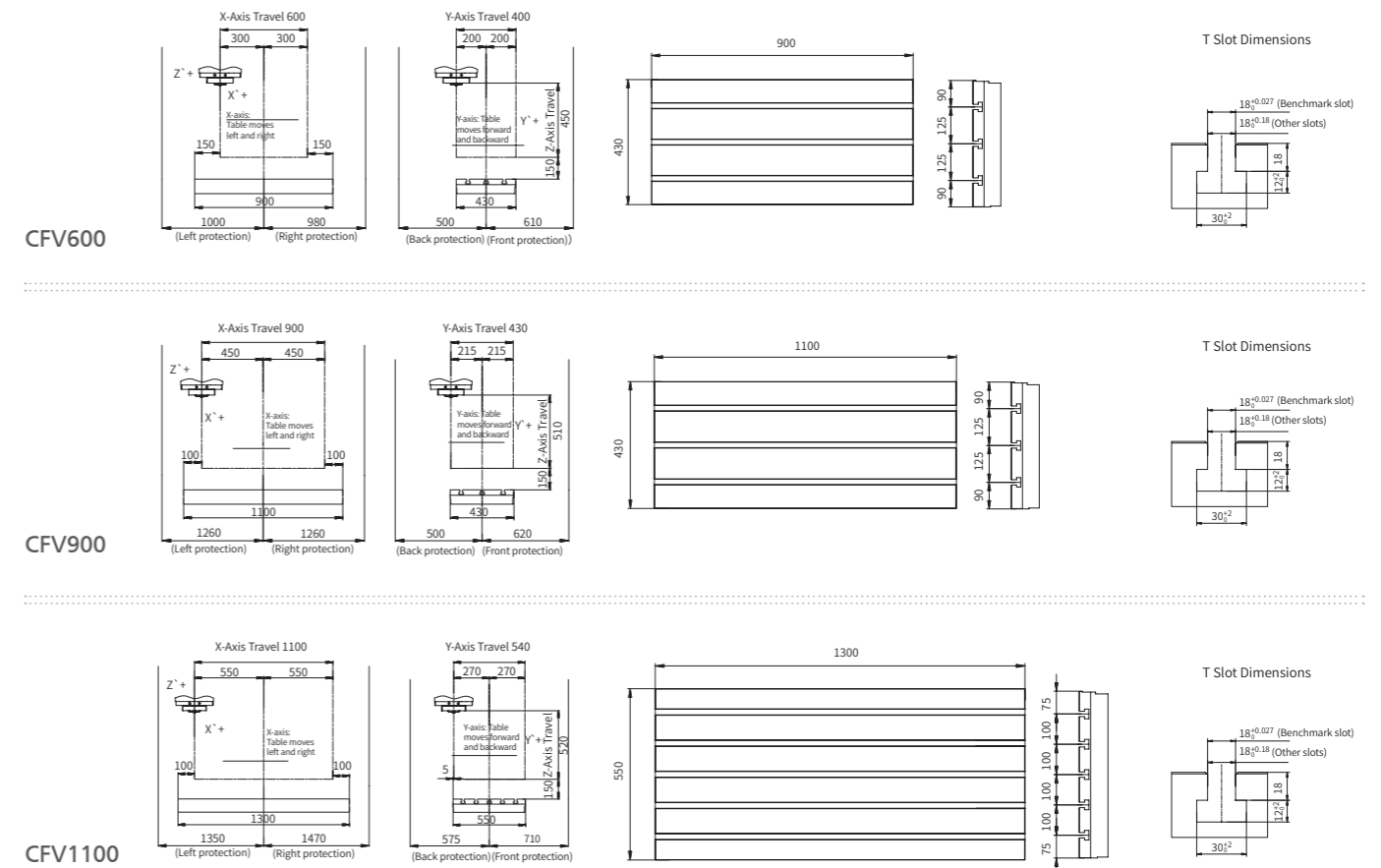

Power-Torque Diagram

Mitsubishi Built-in Spindle (12000rpm)

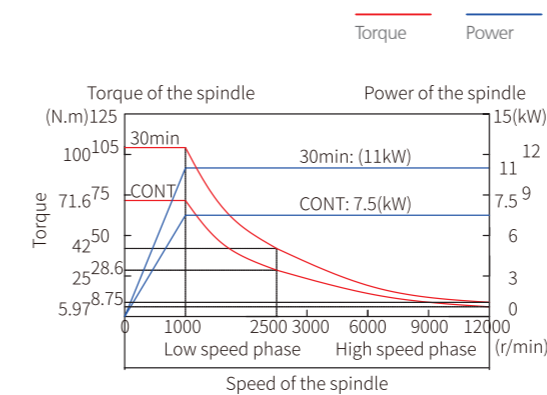

BT40(7: 24) Pull Stud Specification

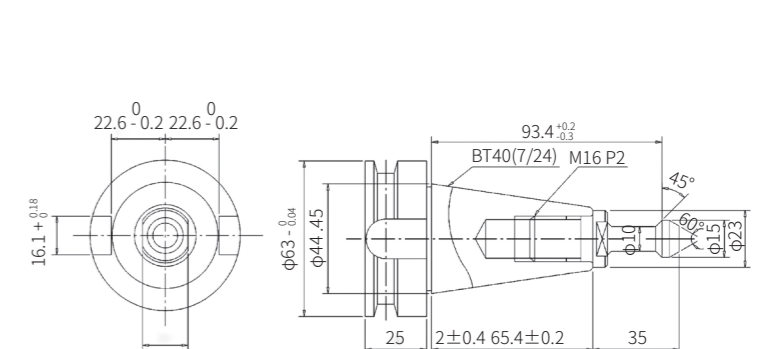



VERTICAL MACHINING CENTER

CFV Lite

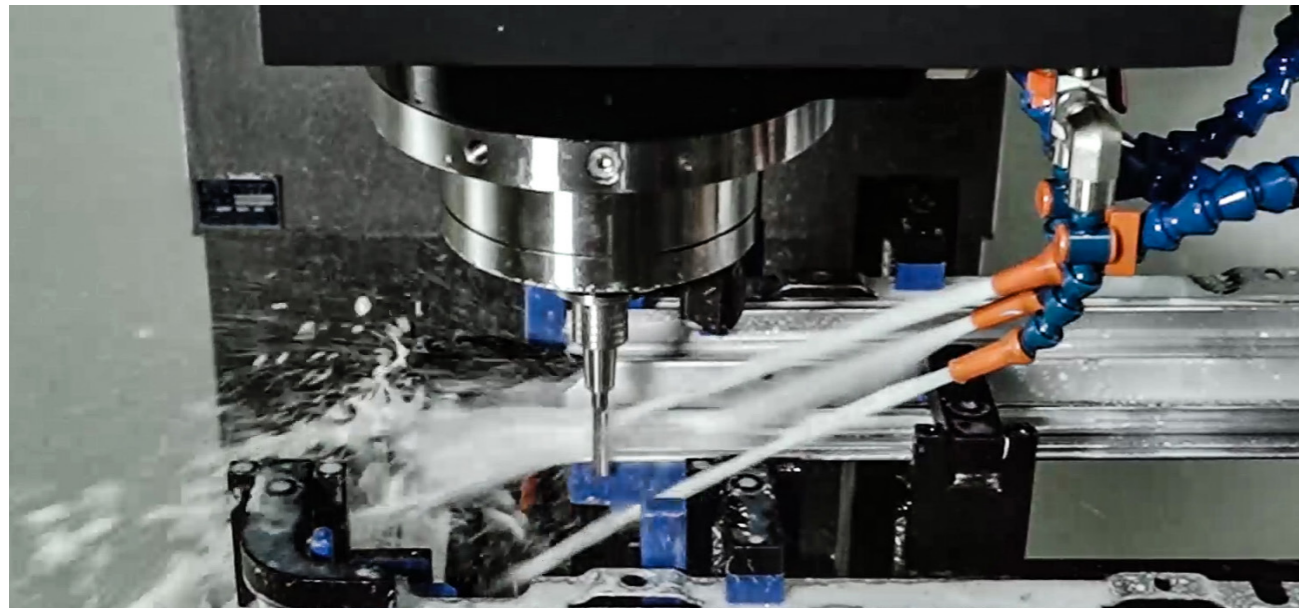

CFV Lite

Small volume, large stroke, spacious processing space, can cope with lightweight large parts, multiple workpiece



CFV Lite

Items	Unit	CFV850Lite	CFV1000Lite	CFV1200Lite
» Machining Capacity				
X travel	mm	850	1000	1200
Y travel	mm	500	600	600
Z travel	mm	500	600	600
Spindle nose to table surface	mm	150-650	150-750	150-750
» Table				
Table size	mm	1000×500	1200×600	1300×600
Table loading	kg	300	400	400
T slot size	mm	5×18×80	5×18×100	5×18×100
» Spindle				
Max. Spindle speed	rpm	16000	16000	16000
Spindle power	kW	7.5/18	7.5/18	7.5/18
Spindle torque	N.m	11.9/17.9	11.9/17.9	11.9/17.9
» Feed Rate				
Rapid traverse(X/Y/Z)	m/min	48/48/36	48/48/36	48/48/36
Cutting feedrate(X/Y/Z)	m/min	20/20/20	20/20/20	20/20/20
» Tool Magazine				
Tool magazine capacity	T	20	20	20
Tool change type		Arm type	Arm type	Arm type
Tool shank type		BT30	BT30	BT30
Max.tool dia. (Adjacent Vacant)	mm	Φ65/Φ120	Φ65/Φ120	Φ65/Φ120
Max. tool length	mm	200	200	200
Max. tool weight	kg	5	5	5
Tool change time (T-T)	s	0.8	0.8	0.8
» Other				
Power capacity	KVA	30	30	30
Machine weight	t	5.7	6.2	6.7
Machine size(L×W×H)(without conveyor)	cm	250×340×255	280×355×270	315×355×270

Standard Configuration

1. Controller: Mitsubishi M80B
2. 16000rpm built-in spindle
3. 20T servo ATC-arm type
4. Spindle oil chiller
5. Cutting cooling (water cooling and air cooling)
6. ATC pneumatic door
7. Internal flush chip system (rear)
8. External hopper type rear water tank
9. Full enclosure with top cover
10. Oil skimmer
11. 3 color signal lamp
12. Air gun

Option Configuration

1. Controller: FANUC Oi
2. 24T servo ATC-arm type
3. Internal screw chip conveyor
4. External chain type chip conveyor
5. Oil mist collector
6. Shower coolant
7. Water gun
8. Tool detection in magazine

LIGHT WEIGHT LARGE ALUMINUM PROCESSING NEW EDGE

CFV Lite SERIES MACHINING CENTER

High Speed
High Rigidity



AS RIGID AS THE BT40 HAS THE EFFICIENCY OF DRILLING AND TAPPING MACHINE

Built-In Spindle To Achieve Fast Installation Center Water

Four Perimeter Perfect Solution

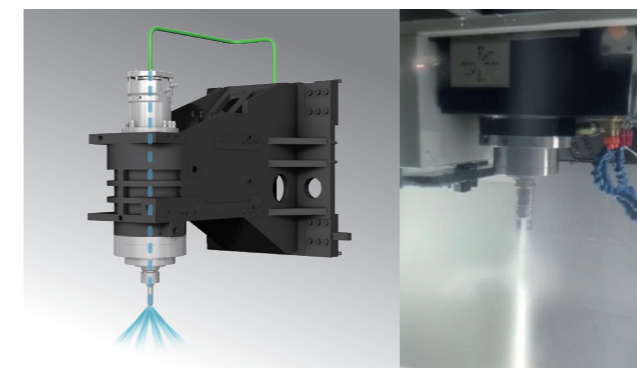

High-Speed Implementation

16000 BBT30-16000rpm built-in spindle 0-6000rpm only need 0.2s	18 Maximum spindle power 18kW	0.8 T-T Tool change time 0.8s (less than 1.5kg)	<ul style="list-style-type: none"> Rapid traverse X/Y/Z 48/48/36m/min; Separate tool magazine, realize the pre-prepared tool, ensure tool changing efficiency, the maximum can be extended to 30T, and does not affect the tool changing efficiency. To realize the sequential processing of lightweight large complex parts; Standard Built-in spindle with Coolant through spindle, can be quickly installed to realize the center outlet, greatly improve the cutting efficiency and reduce tool loss
--	---	---	---

High Rigidity Implementation

- Equipped with BT40 machining center of high rigid structure, wide bed, a type long span column, lightweight headstock;
- Spindle taper standard BBT double - sided restraint interface;
- The 18kW maximum power support beyond the BT40 spindle provides enough power for efficient machining;
- Super broach force design, with accumulator normally closed hydraulic punching mechanism, to achieve high efficiency and stability



 4 Into 4 Out Pneumatic Valve Group and M Code	 Airtight Detection Set	 Oil Mist Collector	 Angle Head
 Spindle Ring Spray	 Shower Coolant	 Tool Setter	 External Oil Mist Cooling Of The Tool



HORIZONTAL MACHINING CENTER

HPC II

The high-speed horizontal Machining center of HPC II series is a new high-end product integrated with the international advanced design concept. The structure of the rib cavity is optimized by analyzing and calculating the basic large components. The thick one-piece bed, combined with a three-axle heavy roller guide and an integrated high-speed motorized spindle, can handle a wide range of material processing from high-speed and high-precision to heavy processing and from aluminum and steel to castings. In addition, high-speed feed servo axes and fast-rotating APCs enable efficient processing to meet your cutting and production efficiency requirements. Product application areas: precision machining in automotive, petroleum, electric power, locomotive, plastic machinery, construction machinery and other industries.



High Rigidity Machine Frame

The design of positive T-shaped integrated high-strength bed and full closed frame symmetrical structure can effectively save the overall accuracy of the machine tool and achieve efficient tool change and work table exchange.

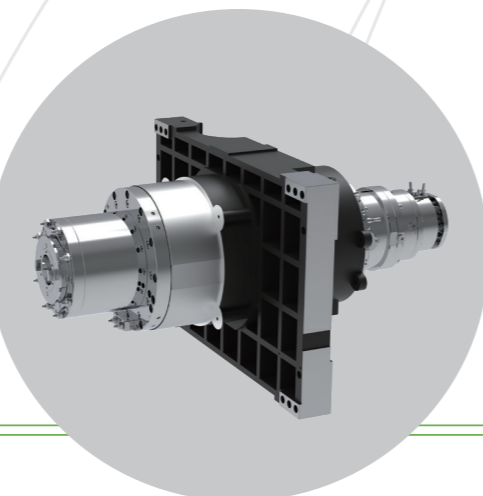

Built-in Spindle

The whole series is equipped with integral built-in electric spindle, which greatly improves the transmission efficiency. Synchronous oil cooling circulation technology is equipped to prevent thermal deformation and ensure stable cutting accuracy.

X/Y/Z Axis Standard Hollow Cooling Screw

The coolant passes through the hollow part of the screw rod to effectively restrain the temperature rise and maintain the accuracy.

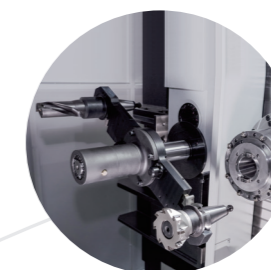
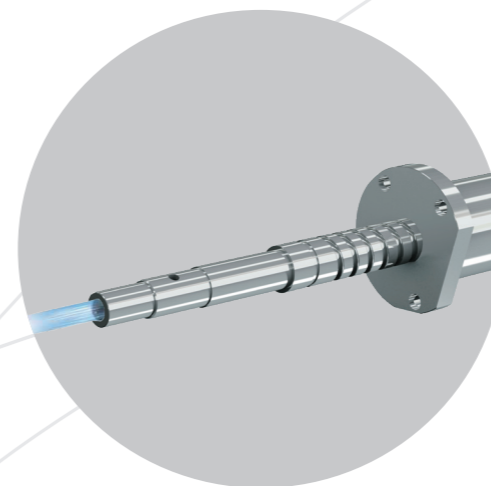

Servo ATC

The tool magazine is driven by servo motor, fixed-point tool change, and the tool magazine move with manipulator simultaneously to effectively shorten the tool change time.

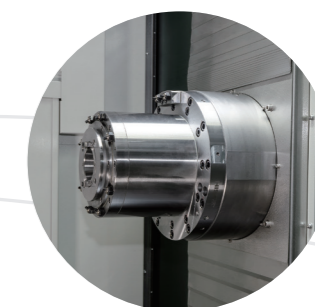

X/Y Axis Shield

The fixed armor protection effectively controls the iron chips and cutting fluid in the fully enclosed processing area, and adapts to the fast and stable operation of moving parts



HPC II

Items	Unit	HPC500 II	HPC600 II	HPC650 II	HPC800 II
» Machining Capacity					
X travel	mm	730	800	1050	1400
Y travel	mm	730	800	900	1200
Z travel	mm	800	850	1000	1050
Spindle center to table surface	mm	80-810	70-870	100-1000	55-1255
Spindle nose to table center	mm	70-870	150-1000	190-1190	200-1250
» Table					
Table size	mm	500×500	630×630	630×630	800×800
Table indexing	°	1°×360	1°×360	1°×360	1°×360
Table load	kg	500	1000	1300	2000
» Spindle					
Drive type		Built-in spindle	Built-in spindle	Built-in spindle	Built-in spindle
Spindle power	kW	18.5/37	26/45	26/45	26/45
Spindle speed	r/min	12000	8000	8000	8000
Spindle torque	Nm	95.5/250	305/623	305/623	305/623
Spindle taper		ISO7:24NO.40	ISO7:24 NO.50	ISO7:24 NO.50	ISO7:24 NO.50
Pull stud		P40T-I-MAS403	P50T-2-MAS403	PT50T-2-MAS403	PT50T-2-MAS403
» Feed Rate					
Rapid traverse(X/Y/Z)	m/min	60	60	60	50
Cutting feedrate(X/Y/Z)	m/min	60	60	60	50
Pallet 90° indexing time	s	1.4	2.5	2.5	3.5
» APC					
Pallet change type		Direct rotary type	Direct rotary type	Direct rotary type	Direct rotary type
Pallet change time		9	10	12	15
» Tool Magazine					
Tool magazine capacity	T	40	40	40	60
Tool selection mode		Shortest path	Shortest path	Shortest path	Shortest path
Tool shank type		BT40	BT50	BT50	BT50
Max. tool length	mm	500	600	600	500
Max. tool dia. (Adjacent Vacant)	mm	Φ80/Φ160	Φ125/250	Φ125/250	Φ125/250
Max. tool weight	kg	12	25	25	25
Tool change time (T-T)	s	1.5	2	2	2
» Other					
Power capacity	kVA	64	64	64	64
Machine weight	t	10	15	19	25
Machine size(L×W×H)	cm	644×310×300	720×310×310	755×398×340	700×530×405

Standard Configuration

1. Controller: FANUC 0i MF PLUS
2. 40T ATC (HPC800II 60T)
3. 1° indexing pallet
4. APC (Auto pallet change)
5. Full enclosure with top cover
6. Guide rail protection
7. External chain type chip conveyor
8. Cutting cooling
9. Spindle oil chiller
10. Screw cooling oil temperature control device

11. Spindle blowing
12. Automatic power-off device
13. Self diagnosis function
14. 3-color signal lamp
15. Standard accessories

HPC II/D

Items	Unit	HPC600II/D	HPC 650II/D	HPC800II/D	HPC1000
» Machining Capacity					
X travel	mm	800	1050	1400	1450
Y travel	mm	800	900	1250	1250
Z travel	mm	850	1000	1250	1250
Spindle center to table surface	mm	100-900	100-1000	55-1255	190-1440
Spindle nose to table center	mm	150-1000	190-1190	200-1450	-200-1050
» Table					
Table size	mm	630×630	630×630	800×800	1250×1000
Table indexing	°	0.001°	0.001°	0.001°	0.001
Table load	kg	1000	1300	2000	2000
» Spindle					
Drive type		Built-in spindle	Built-in spindle	Built-in spindle	Built-in spindle
Spindle power	kW	26/45	26/45	26/45	26/45
Spindle speed	r/min	8000	8000	8000	8000
Spindle torque	Nm	305/623	305/623	305/623	305/623
Spindle taper		ISO7:24 NO.50	ISO7:24 NO.50	ISO7:24 NO.50	ISO7:24 NO.50
Pull stud		PT50T-2-MAS403	PT50T-2-MAS403	PT50T-2-MAS403	PT50T-2-MAS403
» Feed Rate					
Rapid traverse(X/Y/Z)	m/min	60	60	50	60
Cutting feedrate(X/Y/Z)	m/min	60	60	50	20
Pallet 90° indexing time	s	2.5	2.5	3.5	3.5
» Tool Magazine					
Tool magazine capacity	T	40	40	40	40
Tool selection mode		Shortest path	Shortest path	Shortest path	Shortest path
Tool shank type		BT50	BT50	BT50	BT50
Max. tool length	mm	600	600	600	500
Max. tool dia. (Adjacent Vacant)	mm	Φ125/250	Φ125/250	Φ125/250	Φ115/230
Max. tool weight	kg	25	25	25	25
Tool change time (T-T)	s	2	2	2	2
» Other					
Power capacity	kVA	64	64	64	64
Machine weight	t	14	17	23	30
Machine size(L×W×H)	cm	620×310×310	680×398×340	540×530×405	625×430×355

Standard Configuration

1. Controller: FANUC 0i MF PLUS
2. 40T ATC
3. NC table 0.001° indexing
4. Single pallet
5. Full enclosure with top cover
6. Guide rail protection
7. External chain type chip conveyor
8. Cutting cooling
9. Spindle oil chiller
10. Screw cooling oil temperature control device

11. Spindle blowing
12. Automatic power-off device
13. Self diagnosis function
14. 3-color signal lamp
15. Standard accessories

Power Torque Diagram

HPC500 II Standard

Spindle torque
Spindle power

• 12000rpm-FANUC

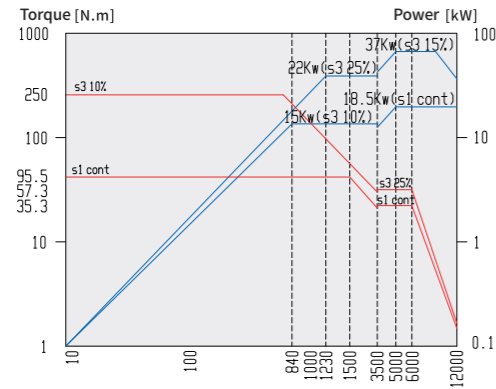

• 12000rpm-SIEMENS

OPTION

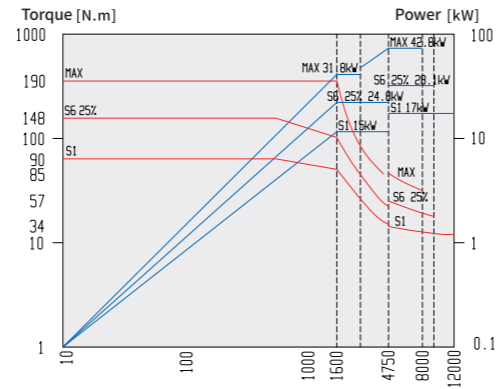

HPC600 II HPC650 II HPC800 II HPC1000 Standard

Spindle torque
Spindle power

• 8000rpm-FANUC

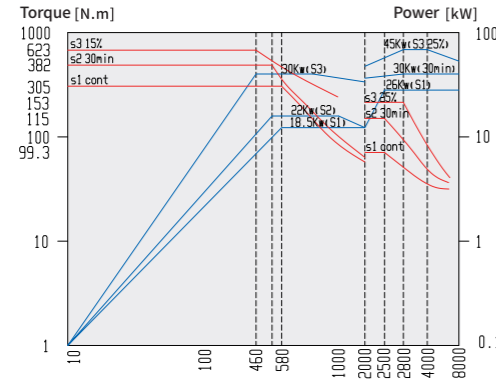

• 8000rpm-SIEMENS

OPTION

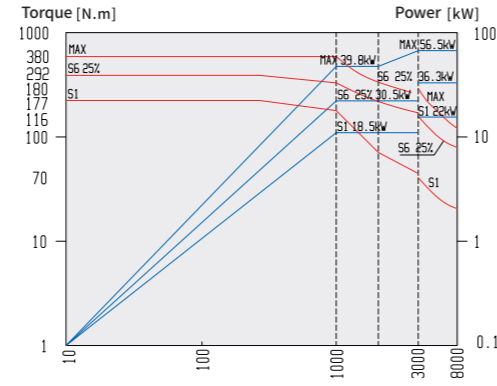

• 12000rpm-FANUC

OPTION

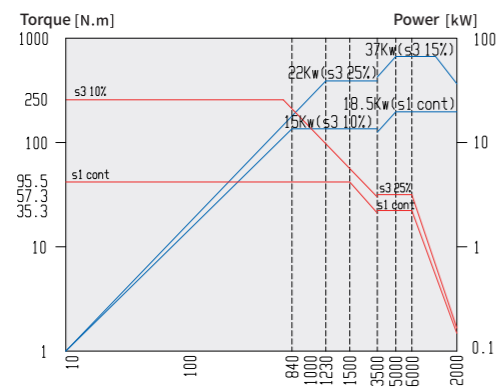

• 12000rpm-SIEMENS

OPTION

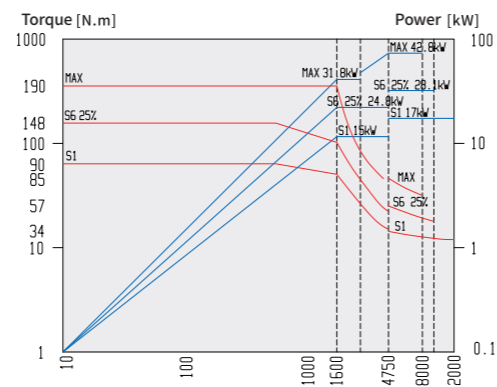

Workpiece Clamping Range

Model	Unit	HPC500 II	HPC600 II	HPC650 II	HPC800 II	HPC1000
Exchange pallet size	mm	500×500	630×630	630×630	800×800	1250×1000
Max.workpiece size	mm	Φ800×1000	Φ900×1000	Φ1100×1170	Φ1450×1320	Φ1920×1500
Max.table loading capacity	kg	500	1000	1300	2000	2000

Pallet Size

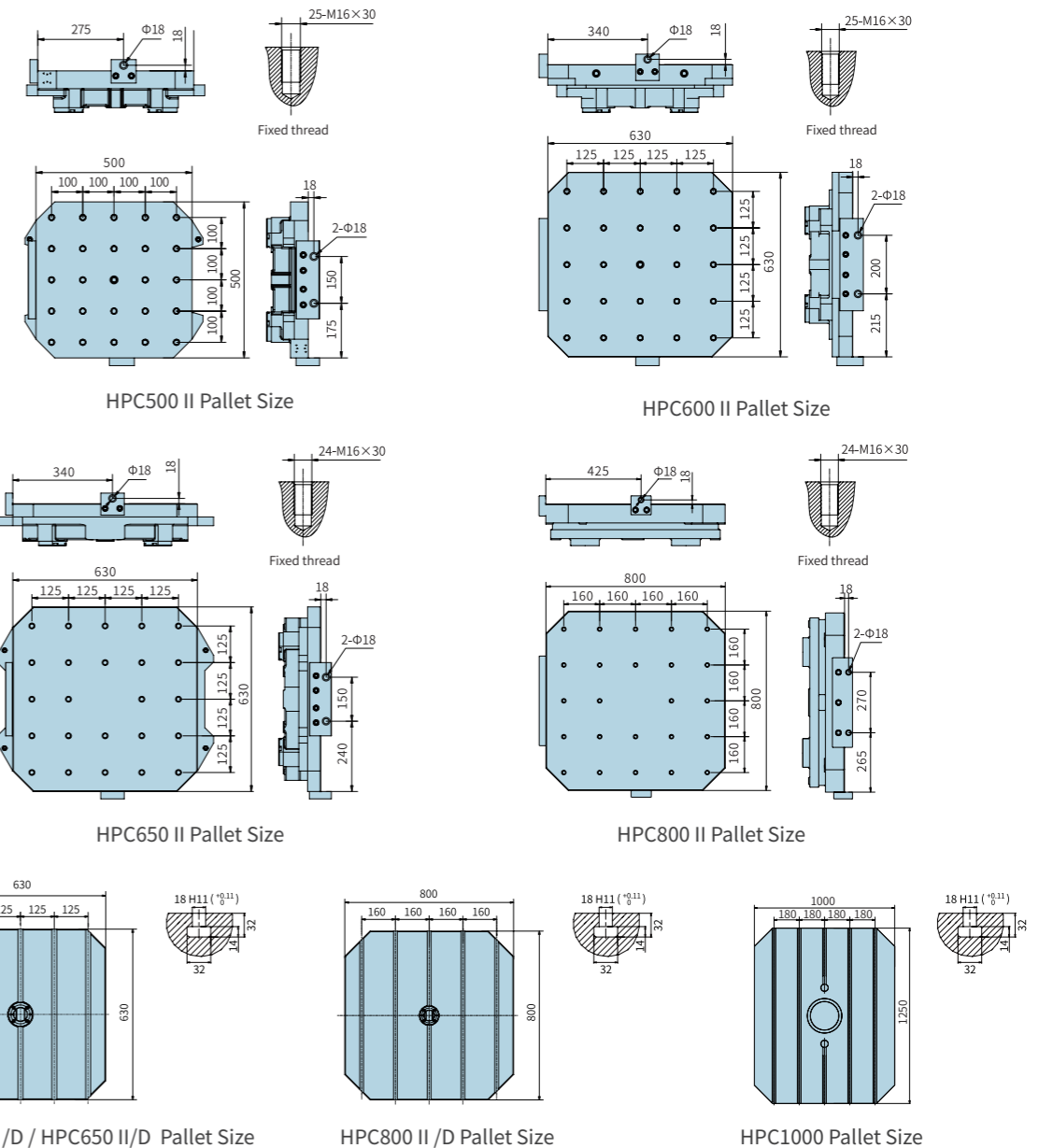



HIGH-SPEED MOVING COLUMN MILLING CENTER FOR STRUCTURAL PARTS

BEL / BFL



BEL

The equipment is suitable for processing large aluminum alloy parts, mainly suitable for new energy vehicles, rail transit, general machinery and other profiles, frames, flat parts processing, such as battery tray, door frame and so on.

BFL (3+2)

This equipment is suitable for the processing of complex large aluminum alloy parts, mainly suitable for the multi-angle processing of large die-cast aluminum alloy parts and structural parts such as battery tray, door frame, instrument panel bracket of new energy vehicles.

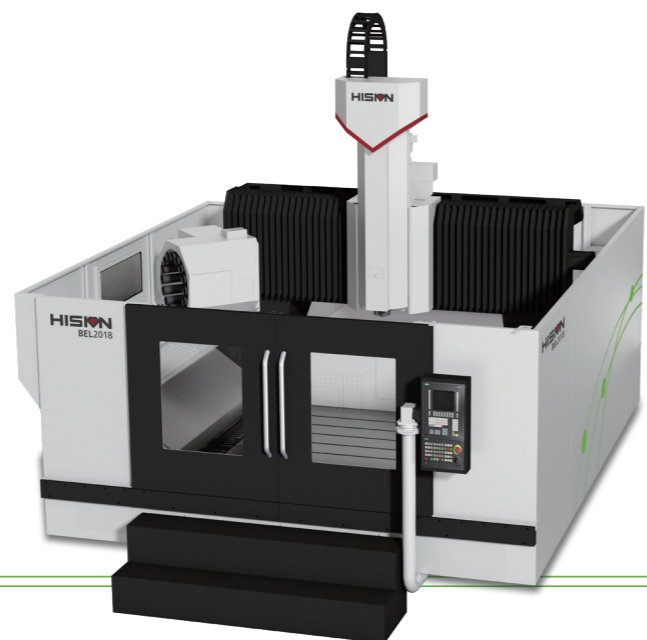

BEL / BFL

Items	Unit	BEL2018	BEL2030	BFL2018	BFL2030
» Machining Capacity					
X travel	mm	1800	3000	1800	3000
Y travel	mm	2000	2000	2000	2000
Z travel	mm	700	700	700	700
A rotary range	°	-	-	±90°	±90°
C rotary range	°	-	-	±180°	±180°
Distance between columns	mm	2050	2050	2050	2050
Gantry passing height	mm	950	950	950	950
Spindle nose to table surface	mm	250-950	250-950	250-950	250-950
Spindle horizontal center line to worktable	mm	-	-	512-1212	512-1212
» Table					
Table size	mm	2000×1800	2000×3000	2000×1800	2000×3000
Table loading	t	3.5	6	3.5	6
T slot size		7×18×250	12×18×250	7×18×250	12×18×250
» Feed Rate					
Cutting feedrate(X/Y/Z)	m/min	20/20/20	20/20/20	20/20/20	20/20/20
Rapid traverse(X/Y/Z)	m/min	40/40/36	30/40/36	40/40/36	60/40/36
» Spindle					
Drive type		Built-in spindle	Built-in spindle	Built-in spindle	Built-in spindle
Max. Spindle speed	rpm	12000	12000	24000	24000
Spindle power	kW	11/22	11/22	15/18	15/18
Spindle torque	N·m	63.7/118	63.7/118	19.1/20.9	19.1/20.9
Spindle taper		BT40	BT40	HSK-A63	HSK-A63
» Tool Magazine(Optional)					
Tool magazine capacity	T	24	24	24	24
Tool handle shape		BT40	BT40	HSKA63	HSKA63
Max.tool dia. (Adjacent Vacant)	mm	Φ80/Φ125	Φ80/Φ125	Φ80/Φ125	Φ80/Φ125
Max. tool length	mm	300	300	300	300
Max. tool weight	kg	6	6	6	6
» Other					
Power capacity	kVA	50	50	60	60
Controller		FANUC Oi	FANUC Oi	SIEMENS 828D	SIEMENS 828D
Machine weight	t	21	23	21	23
Machine size(L×W×H)	cm	665×500×400	750×480×400	665×500×400	750×480×400

Standard Configuration

BEL

1. Controller: FANUC Oi
2. HISON 12000rpm built-in spindle
3. Spindle oil chiller
4. Centralized lubrication system
5. Pneumatic system
6. hydraulic system
7. Cutting tool cooling system and large capacity water tank
8. Internal helix chip conveyor
9. External chain type chip conveyor
10. 3-color signal lamp, working light
11. Portable operating cell box
12. Full enclosure without top cover
13. Protective door Safety electronic door lock
14. Common maintenance tools and related documents
15. Floor installation

BFL

1. Controller: SIEMENS 828D
2. 24000rpm HSD five axis head
3. Spindle oil chiller
4. Centralized lubrication system
5. Pneumatic system
6. Cutting tool cooling system and large capacity water tank
7. Internal helix chip conveyor
8. External chain type chip conveyor
9. 3-color signal lamp, working light
10. Portable operating cell box
11. Full enclosure without top cover
12. Protective door Safety electronic door lock
13. Common maintenance tools and related documents
14. Floor installation
15. X axis rack and pinion drive
16. 1MPa external cooling

Option Configuration

BEL

1. Controller: SIEMENS 828D
2. Air conditioner
3. 24/30T servo tool magazine (arm type)
4. X axis rack and pinion drive
5. Automatic door
6. BLUM tool setter
7. BLUM workpiece probe (2D)
8. Water gun
9. Air gun
10. Coolant through spindle (2MPa)
11. Coolant through spindle (3-6MPa)
12. Spindle ring spray
13. Tool break detection in tool magazine
14. Oil skimmer
15. Airtight detection
16. Oil mist cooling(central/external)
17. Guard left/right door open
18. HSK-A63 built-in spindle
19. External chain type chip conveyor

BFL

1. Air conditioner
2. 24/30T servo tool magazine (arm type)
3. Automatic door
4. BLUM tool setter
5. BLUM workpiece probe (2D)
6. Water gun
7. Air gun
8. Tool break detection in tool magazine
9. Oil skimmer
10. Airtight detection
11. Oil mist cooling(central/external)
12. Guard left/right door open
13. Regulated power supply
14. External chain type chip conveyor

BEL / BFL HIGH-SPEED MOVING COLUMN MILLING CENTER FOR STRUCTURAL PARTS

Working Area

	BEL2018	BEL2030	BFL2018	BFL2030
Table (mm)	2000×1800	2000×3000	2000×1800	2000×3000
Travel (mm)	1800×2000×700	3000×2000×700	1800×2000×700	3000×2000×700



Thin Wall Panel

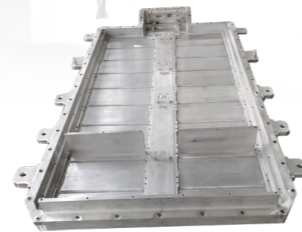

New Energy Battery Pack Chassis

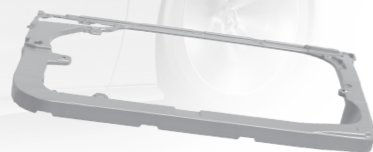

Car Door Frame



Car Rack

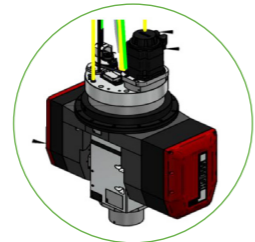

Car Front and Rear Rail

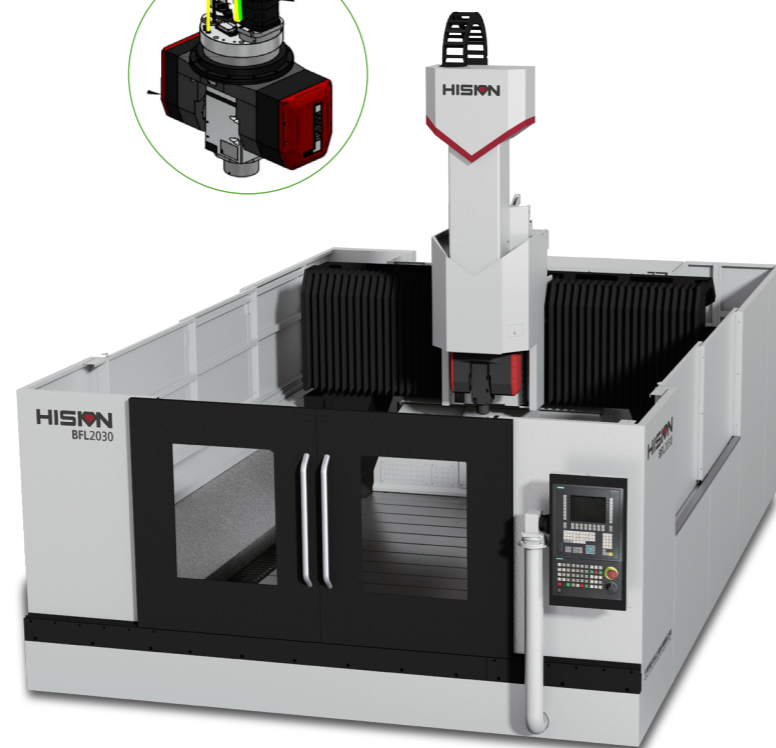

Technical Advantages

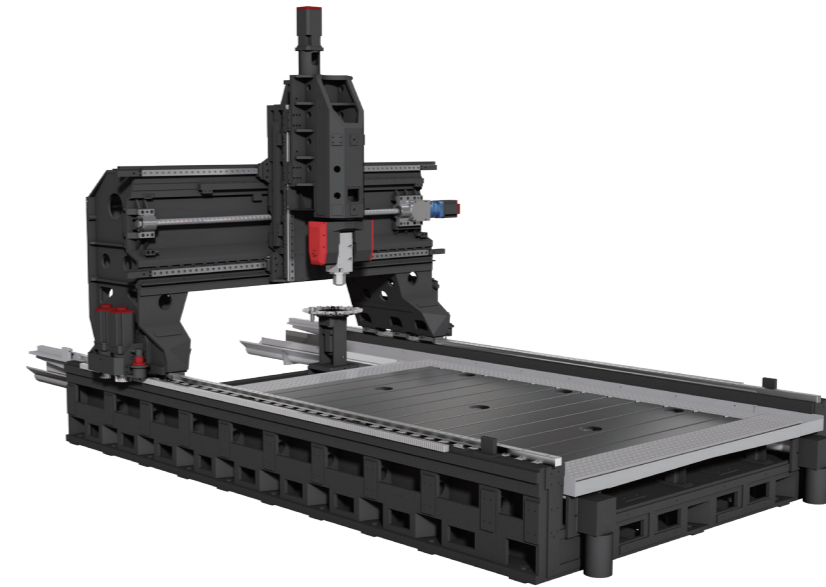

A/C head can be retracted into the sliding saddle to shorten the height of the column beam and improve the rigidity of the machine tool.



High speed moving structure of beam column integrated gantry frame

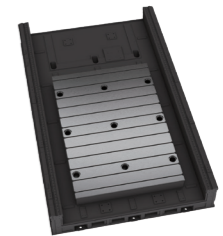

Integral worktable bed

Processing Range

BEL2018/BEL2030
(Cross beam tool magazine)

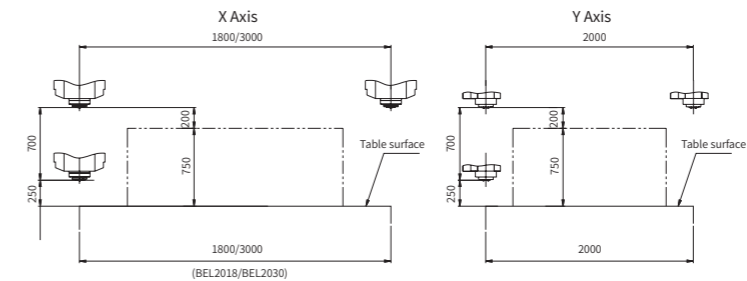

BFL2018/BFL2030
(Cross beam tool magazine)

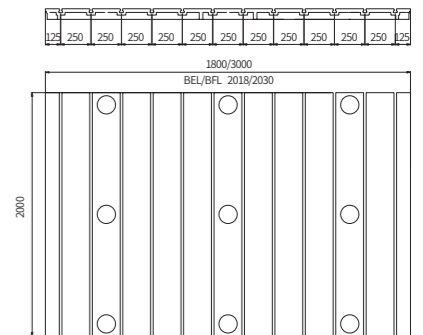
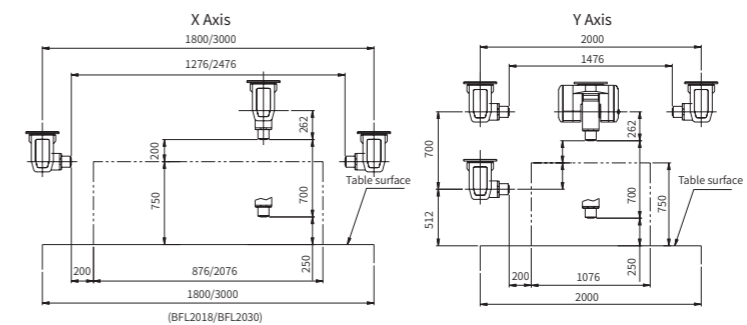

T Slot Dimensions

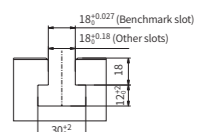



LONG TRAVEL VERTICAL MACHINING CENTER

CHM



CHM

Three-axis machine tool with fixed table and moving spindle. Easier access to workstations. The equipment can be equipped with four axis turntable, suitable for hole and surface processing of strip parts.

CHM-B

Three axis + rotating spindle head (B axis) machine tool with fixed table and moving spindle. The equipment can be equipped with four axis turntable, suitable for aluminum alloy strip parts arc surface and tilt Angle of the hole, surface processing.



CHM

Items	Unit	CHM55020	CHM55025	CHM55020B	CHM55025B
» Machining Capacity					
X-axis travel	mm	2050	2550	2050	2550
Y-axis travel	mm	550	550	550	550
Z-axis travel	mm	520	520	520	520
B axis rotation range	°	--	--	±100°	±100°
Distance from spindle vertical end face to work table	mm	250-770	250-770	330-850	330-850
Distance from spindle horizontal center line to work table	mm	--	--	556-1076	556-1076
B axis rotation speed	r/min	--	--	10	10
» Table					
Table size(A×B)	mm	550×2500	550×3000	550×2500	550×3000
Table load	kg	1000	1000	1000	1000
T slot(slot number × width × distance)	mm	5×18×100	5×18×100	5×18×100	5×18×100
» Spindle					
Drive type		Built-in spindle	Built-in spindle	Built-in spindle	Built-in spindle
Spindle speed	rpm	12,000	12,000	15,000	15,000
Spindle power (continuous 30 minutes overload)	kW	11/19	11/19	11/18.5	11/18.5
Spindle torque (continuous 30 minutes overload)	N.m	69/109	69/109	15/29	15/29
Spindle taper	--	BT40	BT40	BBT30	BBT30
Pull stud specifications	--	MAS-P40T-I	MAS-P40T-I	MAS P30T-I(45°)	MAS P30T-I(45°)
» Feed Rate					
Rapid traverse (X/Y/Z)	m/min	40/36/36	36/36/36	40/36/36	36/36/36
Cutting feedrate (X/Y/Z)	m/min	20/20/20	20/20/20	20/20/20	20/20/20
» Tool Magazine					
Tool magazine capacity	T	24	24	24	24
Tool magazine type		Arm type	Arm type	Arm type	Arm type
Tool holder		BT40	BT40	BT30	BT30
Max.tool dia. (Adjacent vacant)	mm	Φ63/Φ80	Φ63/Φ80	Φ63/Φ80	Φ63/Φ80
Max.tool length	mm	300	300	250	250
Max.tool weight	kg/T	7	7	5	5
Tool change time (T-T)	s	1.5	1.5	--	--
» Other					
Controller		SIEMENS 828D	SIEMENS 828D	SIEMENS 828D	SIEMENS 828D
Air pressure	MPa	0.5 ~ 0.7	0.5 ~ 0.7	0.5 ~ 0.7	0.5 ~ 0.7
Power capacity	V/Hz	380V/50Hz	380V/50Hz	380V/50Hz	380V/50Hz
Machine size	mm	5500×3425	6500×3425	5500×3425	6500×3425

Standard Configuration

CHM

1. Controller:SIEMENS 828D
2. HISION built-in spindle
3. 24T tool magazine (arm type)
4. X/Y/Z triaxial protective pull plate
5. Spindle cooling system
6. Pneumatic, hydraulic and lubrication system
7. Cutting cooling
8. Artifacts air-cooled
9. 3-color signal lamp, working light
10. Pneumatic tool change protective door
11. Full enclosure with top cover
12. Internal flush chip system
13. External chain type chip conveyor
14. Platen foundation
15. Standard accessories

CHM-B

1. Controller:SIEMENS 828D
2. HISION built-in spindle
3. HISION B axis
4. 24T tool magazine (arm type)
5. X/Y/Z triaxial protective pull plate
6. Spindle cooling system
7. Pneumatic, hydraulic and lubrication system
8. Artifacts air-cooled
9. 3-color signal lamp, working light
10. Pneumatic tool change protective door
11. Full enclosure with top cover
12. Internal flush chip system
13. External chain type chip conveyor
14. Platen foundation
15. Standard accessories

Option Configuration

CHM

1. Controller:FANUC 0I
2. Air conditioner
3. Increase the distance from work table to spindle by 100(Z-axis stroke remains unchanged)
4. 30T servo tool magazine
5. Automatic door
6. Nc rotary table
7. Workpiece probe(2D)
8. Tool setter
9. Water gun
10. Coolant through spindle (2MPa)
11. Coolant through spindle (3-6MPa)
12. Spindle ring spray
13. Tool break detection in tool magazine
14. Oil mist collector
15. Oil skimmer
16. Airtight detection
17. External chip conveyor with recoil drum
18. Fixture flush

CHM-B

1. Air conditioner
2. 30T servo tool magazine
3. Automatic door
4. Nc rotary table
5. Workpiece probe (2D)
6. Tool setter
7. Water gun
8. Coolant through spindle (2MPa)
9. Tool break detection in tool magazine
10. Oil mist collector
11. Oil skimmer
12. Airtight detection
13. External chip conveyor with recoil drum
14. Fixture flush

CHM LONG TRAVEL VERTICAL MACHINING CENTER

Working Area

	CHM55020/B	CHM55025/B
Table (mm)	550×2500	550×3000
Travel (mm)	2050×550×520	2550×550×520

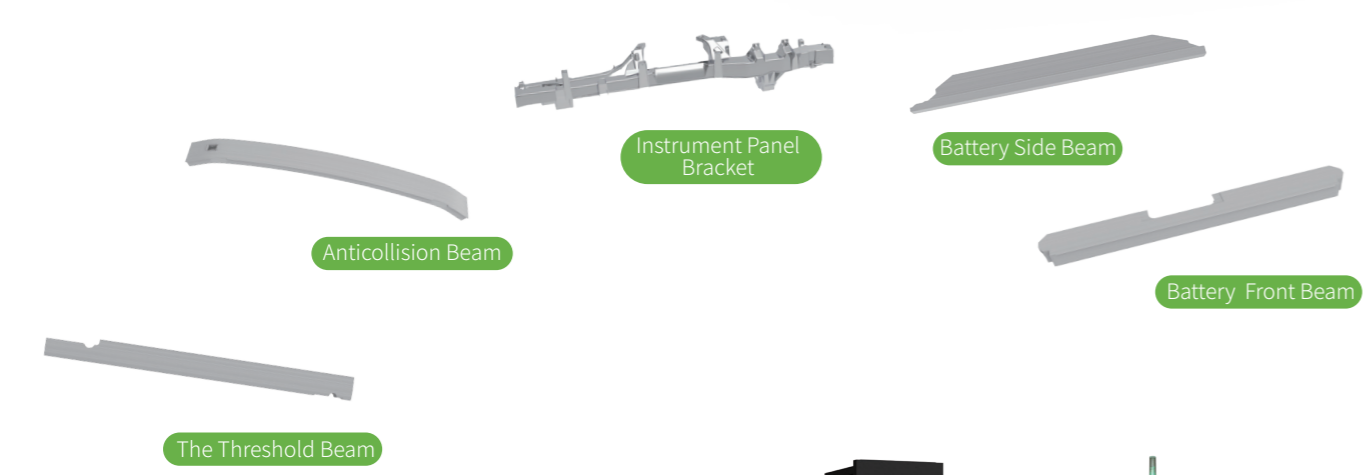

Technical Advantages

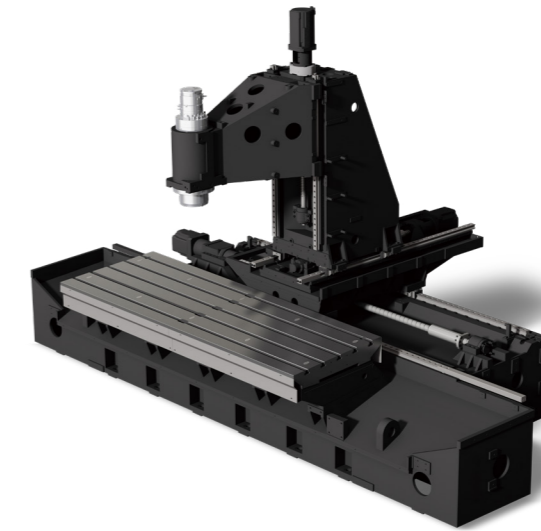

High Speed, High Precision Built-In Spindle

- High precision: built-in motor direct drive, no other vibration source.
- Efficient start and stop: "zero" transmission, small inertia, matched with instantaneous high-power output stator, 0 to 8000 turn start only 0.8s.



24T Servo Tool Magazine

- Intelligent tool preparation mode: buffer tool, effectively protect the spindle.
- Automatic protection door is configured to effectively isolate the impurities such as iron filings from entering the tool sleeve, affecting the machining accuracy.
- T-T time 1.2s.
- Standard 24T servo tool magazine, capacity can be expanded to 30T.



Easy To Operate Design

- Workbench fixed, spindle moving way, easier access to the workbench, convenient workpiece loading and unloading and adjustment.
- The rotating operation panel is suitable for different operators.
- Large open sliding door structure is convenient for lifting workpieces.

Processing Range

CHM55020/CHM55025

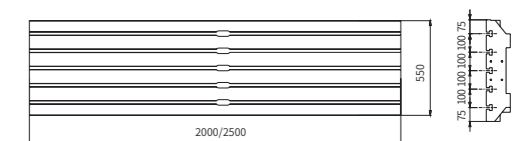
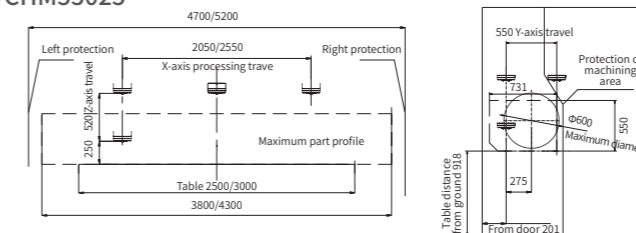

CHM55020B/CHM55025B

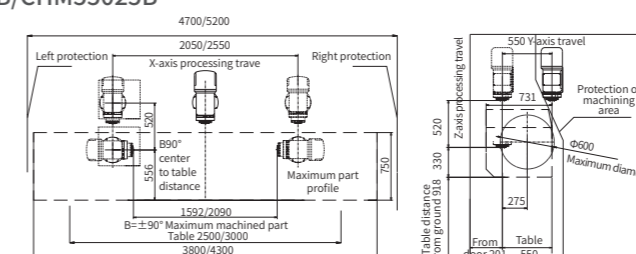

T Slot Dimensions

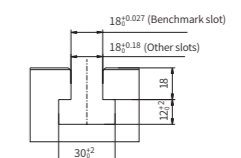



MORE THAN PRECISION

Ningbo Haitian Precision Machinery Co., Ltd. is a listed company specializing in machine tooling industry. It has developed Ningbo Dagang production base, Ningbo Yanshan production base and Dalian production base. It has a modern constant temperature processing and assembly plant of over 300,000 square meters with nearly 1900 employees. It is awarded honors such as “national major technical equipment enterprise”, “national high-tech enterprise”, and “provincial high-tech research and development center”.

